

~for Whiskey/Brandy/Gin~ Pot Stills type - ADC



ADC-3000-2



ADC-1000-WS



AD-1000 (Simple copper specification type)

Full-fledged pure copper distillation equipment

From a small size of 50 liters to a medium size of 3000 liters, we will design according to your request.

Various types such as internal split receiving tanks, branch piping, sample cock, alcohol meters, etc. prepare your options.

We will respond to all your requests.

Only the head/swan neck (line arm) and condenser: tube type It is also possible to manufacture a simple mold made of copper (right photo). It is also possible to manufacture a simple model in which only the head/swan neck (line arm) and condenser (tube type) are made of copper (upper photo).

~Short description~

This is a full-fledged atmospheric distillation system that follows the traditional distillation method.

The inside of the distillation kiln is equipped with both a coil for indirect heating and a live steam blowing tube as standard.

The elegant design also has the qualities of an interior.

It is said that the shape and angle of the gooseneck, line arm, etc. have a great influence on the taste of the product.

We will respond to the customer's request as much as possible in terms of length and shape.



~Versatile options~

- Special specifications for use in mash distillation: Cleaning nozzles, wire mesh demisters, etc.
- To save cooling water... Cooling Towers & Circulation Pumps
- Internally split product receptacle: For Head, Heart and Tail
- Alcohol meter, branch piping
- Automatic control of steam valves and other automatic controls
- CIP (clean-in-place), Washing Pump, shower balls, etc.
- Scaly buff finish: Receiving tank, skirt, etc.

Copper atmospheric distillation unit ADC-type

- We will make it to order even if it is a size other than the standard size
- The condenser uses a tube type, which has excellent cleanability and heat transfer efficiency
- The heater is made of stainless steel, so it is durable and long-lasting
- With the beauty of copper, the catalytic (reducing action) effect, and the good heat conductivity can be fully demonstrated
- We also respond to special specifications (material, heating method, polishing finish, reflux, reservoir, etc.)

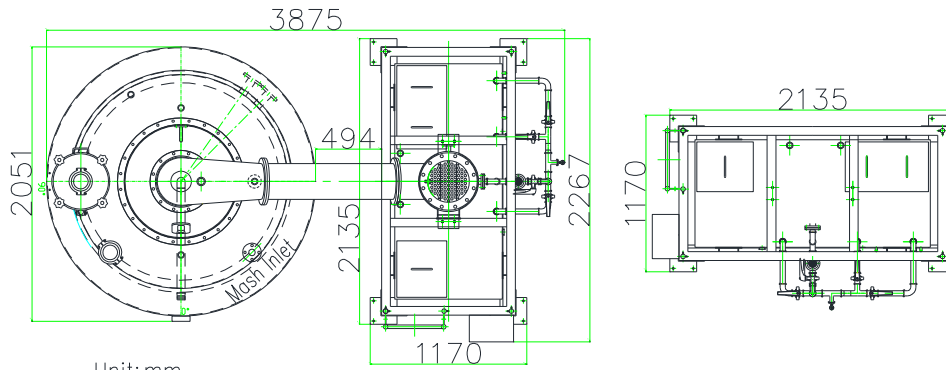

Unit: mm



ADC-50

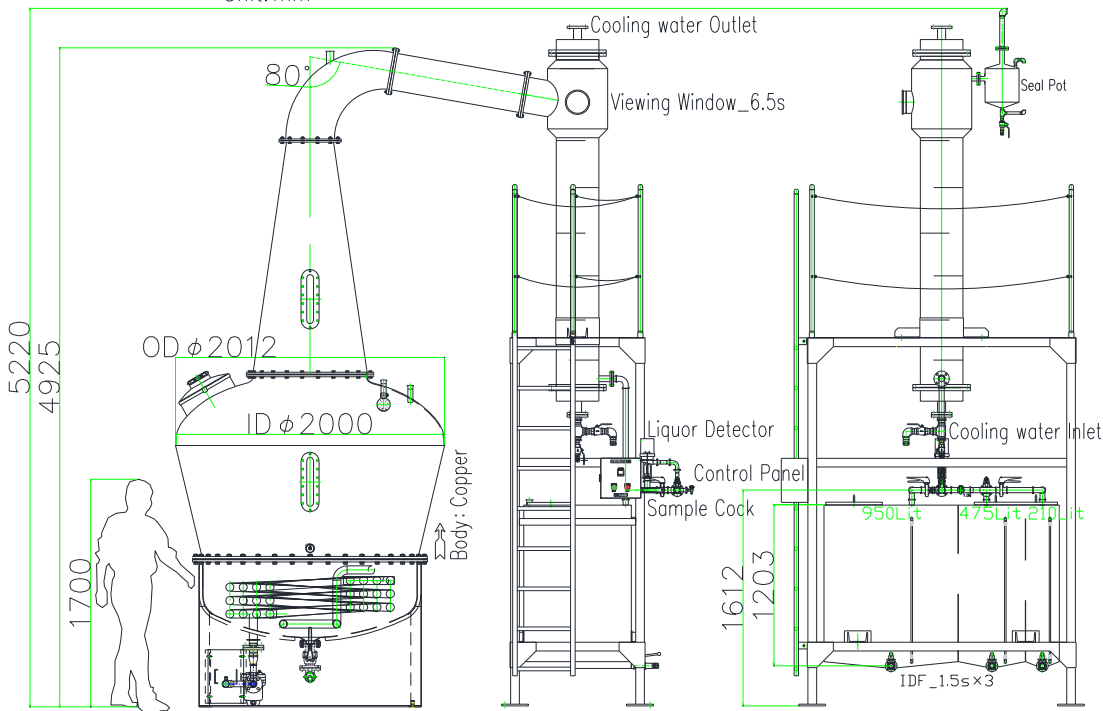

ADC-3000-WS

Specification/Model	ADC-50	ADC-300	ADC-500	ADC-1000	ADC-3000
Throughput (Lit/time)	50	300	500	1000	3000
Steam(kg/time)X(0.2MPa)	30	180	300	600	1800
Cooling water(ton/h)(under 20°C)	0.1	0.6	1	2	6
Reference installation Dimensions	600L x 800W x 1000H	750L x 1500W x 2200H	1000L x 1400W x 2600H	1600L x 1500W x 3100H	4000L x 2300W x 5250H

● Due to product improvement, there is a possibility of specification change without notice.

● Design/Production/Distributor

Yokoyama Engineering Co., Ltd.

〒452-0822 Nakaotai 3-247, Nishi-ku, Nagoya-shi, Aichi Japan

Tel:052-505-5911 Fax:052-505-5915

Email:sakefor@gmail.com URL:https://www.yokoyama-eng.com

● Agency